

i15  
**USER MANUAL**

# **CONTENTS**

1. Introduction
2. Unpacking
3. Connectors/Cabling
4. Polarity Checking
5. Amplification & Power Handling
6. Crossovers
7. Equalisation
8. Dimensions
9. Rigging
10. Performance Data
11. Technical Specifications
12. i15 Recommended Service Parts & Accessories
13. Warranty
14. Wall Mounting Bracket - Assembly Instructions
15. Declaration of Conformity

## 1. Introduction

The Tannoy i15 professional loudspeaker has been designed for a wide variety of sound reinforcement applications requiring extended frequency response from a compact system, capable of delivering high sound pressure levels with extremely low distortion, resulting in outstanding clarity, definition and detail.

The i15 comprises one 15 inch Dual Concentric driver in which the low frequency (LF) and high frequency (HF) sources are coincidentally aligned to a point source, resulting in a smooth uniform frequency response over a wide area of coverage either as a portable stand alone system or in a multi-cabinet array. The sophisticated CAD designed waveguide combines 60 degree conical dispersion and excellent acoustic impedance characteristics. As the system is a point source, clusters and arrays have minimal lobing. These features are inherent and achieved without the use of any electronic signal processing

Designed for fixed installations, the i15 is constructed from medium density fibreboard (MDF), for a high level of acoustic damping. The structural integrity of the enclosure is further enhanced by internal steel braces which double as the flying points accepting M8 eyebolts, strategically placed to distribute the weight of the enclosure evenly.

For applications requiring extended low frequency enhancement, a range of Tannoy sub-bass systems are available and can be used in conjunction with the i15.

## 2. Unpacking

Every Tannoy i15 is carefully inspected before packing. After unpacking your loudspeaker, please inspect for any exterior physical damage, and save the carton and any relevant packaging materials in case the loudspeaker again requires packing and shipping. In the event that damage has been sustained in transit notify your dealer immediately.

## 3. Connectors/Cabling

The i15 is fitted with two 4-pole Speakon™ connectors. Speakon has the following advantages over EP and XLR type connectors: all terminations are solderless, this makes life easier at the time of installation or when field servicing is required. Contacts will accept 6 sq. mm wire with an outside diameter of up to 15mm and a current rating of 30 Amps. The pins of the Speakon sockets identified as input/output on the rear of the input panel are paralleled within the enclosure.

Tannoy have adopted the following wiring standard for the i15 :-

**Pin 1+ is Positive**  
**Pin 1- is Negative**

Should you encounter any problems obtaining Speakon connectors, please contact Neutrik or its distributors directly on the following numbers:-

UK: NEUTRIK MARKETING: 0171 792 8188  
 USA: NEUTRIK USA INC.: (201) 901 9488

For a world wide list of distributors, please contact Neutrik directly:-

NEUTRIK AG: +41 7529666

Cable choice consists mainly of selecting the correct cross sectional area in relation to the cable length and the load impedance. A small cross sectional area would increase the cables series resistance, inducing power loss and response variations (damping factor).

Connectors should be wired with a minimum of 2.5 sq. mm (12 gauge) cable. This will be perfectly satisfactory under normal conditions. In the case of very long cable runs the wire size should exceed this, refer to the following table for guidance:-

CABLE RUN (m)	C.S.A. OF EACH CONDUCTOR (mm)	CABLE RESISTANCE $\Omega$	% POWER LOSS INTO 8 $\Omega$ LOAD	% POWER LOSS INTO 4 $\Omega$ LOAD
10	2.5	0.14	1.7	3.5
	4.0	0.09	1.1	2.2
	6.0	0.06	0.73	1.5
25	2.5	0.35	4.3	8.6
	4.0	0.22	2.7	5.4
	6.0	0.14	1.8	3.6
50	2.5	0.69	8.6	17.0
	4.0	0.43	5.4	11.0
	6.0	0.29	3.6	7.2
100	2.5	1.38	17.0	35.0
	4.0	0.86	11.0	22.0
	6.0	0.58	7.2	14.0

#### 4. Polarity Checking

It is most important to check the polarity of the wiring before the speaker system is used. A simple method of doing this without a pulse based polarity checker for LF units is as follows: Connect two wires to the +ve and -ve terminals of a PP3 battery. Apply the wire which is connected to the +ve terminal of the battery to the speaker cable leg which you believe to be connected to pin 1+ of the speaker connector and likewise the -ve leg of the battery to pin 1-.

If you have wired it correctly the LF drive unit will move forward, indicating the wiring is correct. All that remains now is to connect the +ve speaker lead to the +ve terminal on the amplifier and the -ve lead to the -ve terminal on the amplifier. If however the LF driver moves backwards, the input connections need to be inverted.

If problems are encountered, inspect the cable wiring in the first instance. It should also be noted that different amplifier manufacturers utilise different pin configurations and polarity conventions, if you are using amplifiers from more than one manufacturer, check the polarity at the amplifiers as well as the loudspeakers.

## **5. Amplification & Power Handling**

As with all professional loudspeaker systems, the power handling is a function of voice coil thermal capacity. Care should be taken to avoid running the amplifier into clip (clipping is the end result of overdriving any amplifier). Damage to the loudspeaker will be sustained if the amplifier is driven into clip for any extended period of time. Headroom of at least 3dB should be allowed. When evaluating an amplifier, it is important to take into account its behaviour under low impedance load conditions. A loudspeaker system is highly reactive and with transient signals it can require more current than the nominal impedance would indicate.

Generally a higher power amplifier running free from distortion will do less damage to the loudspeaker than a lower power amplifier continually clipping. It is also worth remembering that a high powered amplifier running at less than 90% of output power generally sounds a lot better than a lower power amplifier running at 100%. An amplifier with insufficient drive capability will not allow the full performance of the loudspeaker to be realised.

It is important when using different manufacturers' amplifiers in a single installation that they have very closely matched gains, the variation should be less than +/- 0.5dB. This precaution is important to the overall system balance when only a single active crossover is being used with multiple cabinets, it is therefore recommended that the same amplifiers are used throughout.

## **6. Crossovers**

The i15 is supplied as standard for passive operation via the internal crossover network. If higher peak outputs are required then the i15 can be used in conjunction with the Tannoy TX2 controller/crossover which provides high pass filtering and a degree of parametric equalisation (see performance data section), as well as a fixed crossover point for use with sub-bass loudspeakers.

## **7. Equalisation**

The i15 is designed to need no equalisation or correction to overcome system limitations. As a result, it will only need equalisation to compensate for difficult acoustic environments.

Excess equalisation can reduce system headroom, and introduce phase distortion resulting in greater problems than it cures. If equalisation is required then it should be applied gently and smoothly. Violent equalisation will be detrimental to the overall sound quality.

## 8. Dimensions

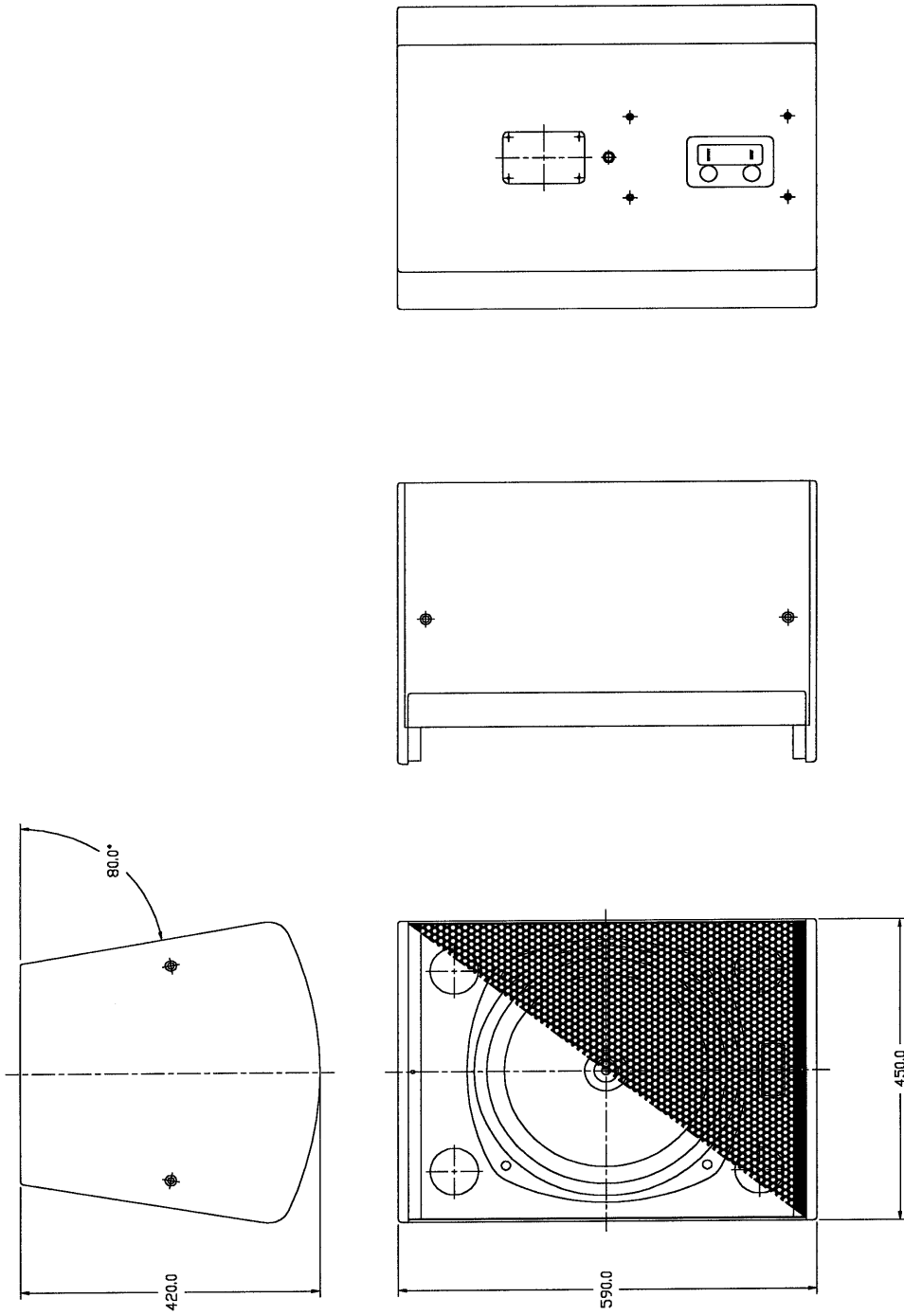

## 9. Rigging

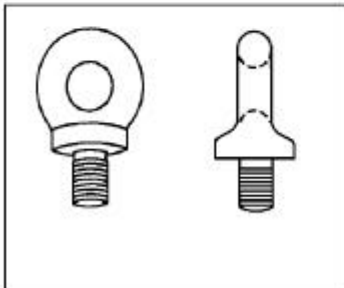
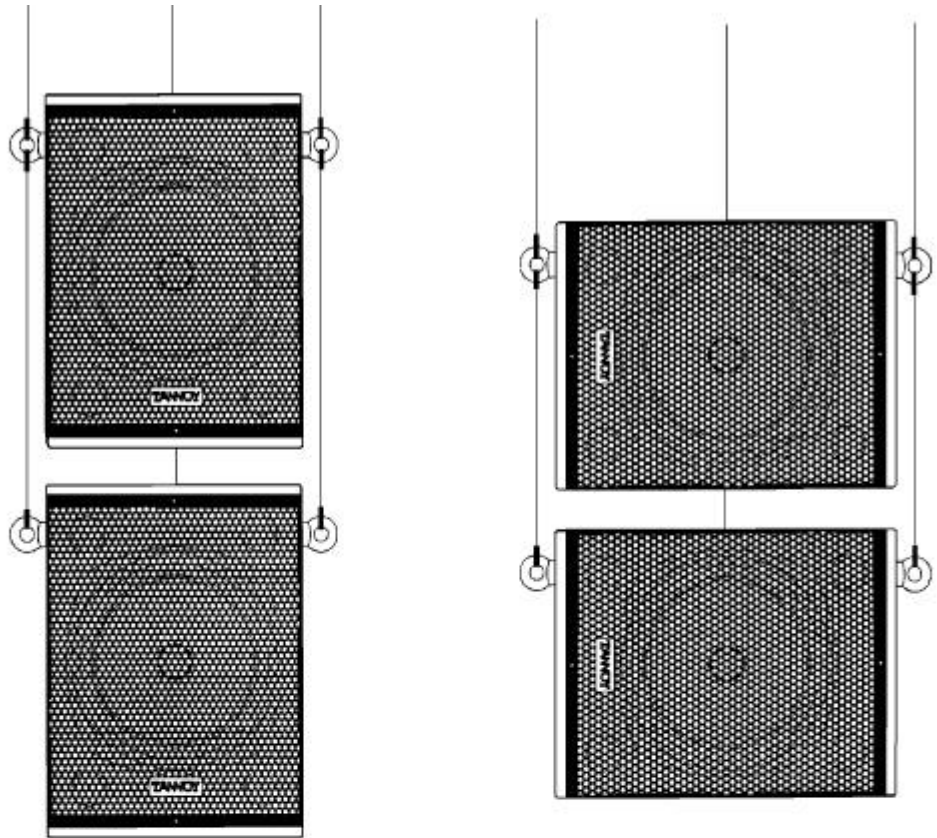

The i15 is flown by using high quality M8 eyebolts with collar to BS4278: 1984. These eyebolts are supplied as part of an optional flying kit and come in packs of three. The i15 is equipped with internal steel braces which also double as the flying points accepting the M8 eyebolts.

Remove two of the original M8 countersunk screws and replace with the eyebolts, the M8 insert in the back of the cabinet also accepts an eyebolt, this is used for tilting the cabinet.

**IMPORTANT:** It is imperative for safety reasons that two eyebolts linked to two independantly fixed straps are used per cabinet. Fly the cabinets as shown above, do not fix the eyebolts to the top of the cabinets. As with any rigging system safety can only be guaranteed when all precautions have been implemented correctly.

**WARNING:** As the legal requirements for flying change from country to country, please consult your local safety standards officer before installing any product. Alternatively, check any laws or bylaws.

## 10. Performance Data

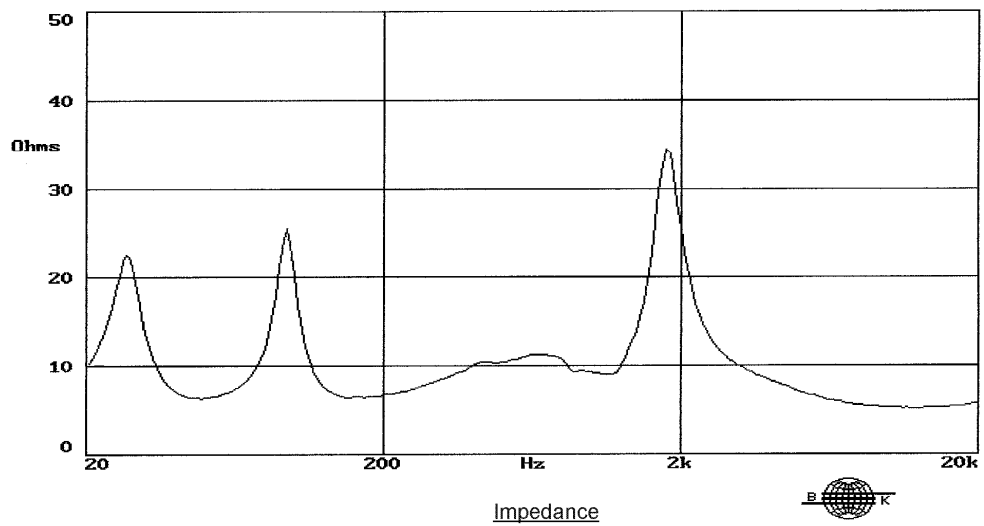
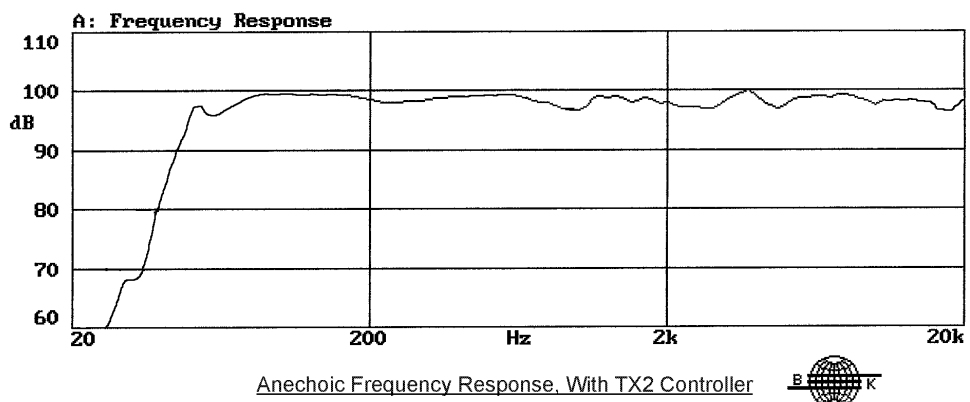
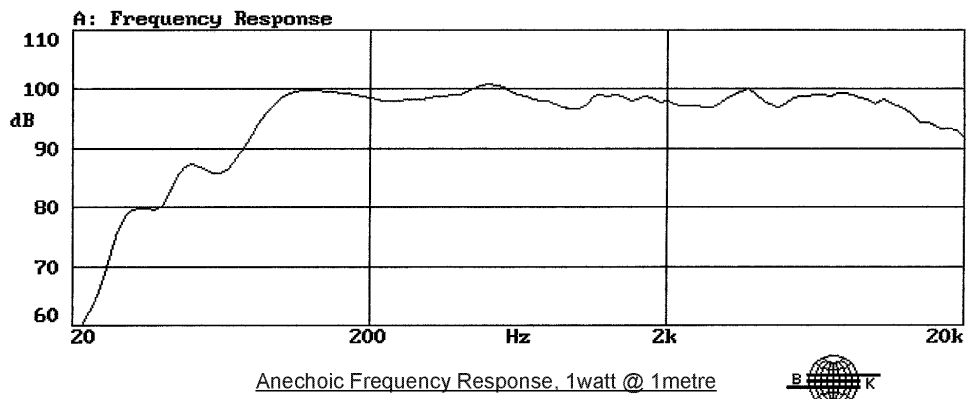



## 11. Technical Specifications

<b>Frequency Response (1) +/- 3dB</b>	60Hz - 22kHz 37Hz - 22kHz (with Tx2 controller)		
<b>Recommended Amplifier Power</b>	250 - 500 watt / 8 ohm		
<b>Power Handling(2)</b>	Average 250 watt	Programme 500 watt	Peak (10ms) 1000 watt
<b>Sensitivity (1) 2.83 volt @ 1m</b>	99 dB		
<b>Maximum SPL (3) @ 1m</b>	Average 123 dB	Peak 129 dB	
<b>Impedance</b>	Nominal Minimum	8.0 ohm 6.0 ohm	
<b>DI Averaged (PCQ)</b>	9.97, 500 Hz - 16 kHz		
@ 1kHz (ISO)	8.5		
@ 2kHz (ISO)	9.1		
@ 4kHz (ISO)	9		
@ 8kHz (ISO)	12.5		
@ 16kHz (ISO)	14.15		
<b>Q Averaged (PCQ)</b>	11.92, 500 Hz - 16 kHz		
@ 1kHz (ISO)	7.1		
@ 2kHz (ISO)	8.1		
@ 4kHz (ISO)	7.9		
@ 8kHz (ISO)	17.8		
@ 16kHz (ISO)	26		
<b>Distortion</b>			
	<b>0.1 Full Power</b>	<b>2nd Harmonic</b>	<b>3rd Harmonic</b>
	250 Hz	0.18%	0.44%
	1000 Hz	1.77%	1.77%
	10000 Hz	1.58%	0.11%
	<b>0.01 Full Power</b>	<b>2nd Harmonic</b>	<b>3rd Harmonic</b>
	250 Hz	0.09%	0.09%
	1000 Hz	0.50%	0.71%
	10000 Hz	0.56%	Below measurement limit
<b>Driver Complement</b>	1 x 15" (381mm) Constant Directivity Dual Concentric Type number 3804		
<b>Crossover Point</b>	Passive 1.6kHz 3 <sup>rd</sup> order high pass, 2 <sup>nd</sup> order low pass Halogen HF protection		
<b>Enclosure</b>	65 litre vented, MDF		
<b>Finish</b>	Textured black\grey paint		
<b>Connectors</b>	2 x Speakon NL4MPR IN/OUT		
<b>Fittings</b>	8 x M8 flying inserts & 1 x M8 pullback point		
<b>Dimensions</b>	590mm(H) x 450mm(W) x 420mm(D) 23.2ins(H) x 17.7ins(W) x 16.54ins(D)		
<b>Weight</b>	24 Kg (52.8 lbs)		

**NOTES:**

- (1) Average over stated bandwidth. Measured at 1m on axis, in an anechoic chamber.
- (2) Long term power handling capacity as defined in EIA standard RS - 426A.
- (3) Unweighted pink noise input, measured at 1m in half space conditions.

Tannoy operate a policy of continuous research and development. The introduction of new materials or manufacturing methods will always equal or exceed the published specifications which Tannoy reserve the right to alter without prior notice. Please verify the latest specifications when dealing with critical applications.

## 12. i15 Service Parts & Accessories

<b>Part Number</b>	<b>Description</b>
7900 0463	Driver Kit - 3804
7900 0464	Recone Kit - 3804
7900 0199	HF Diaphragm Kit
7300 0570	Crossover Kit - 1225
7900 0442	Paint - Touch up Black-Grey
8000 0647	Flying Kit ( 3 x M8 Eyebolts )
8000 0671	Wall Mounting Bracket
8000 0630	TannoyTX2 Active System Controller/2-way Stereo Crossover

## 13. Warranty

No maintenance of the i15 loudspeaker is necessary.

All Tannoy professional loudspeaker products are covered by a 5 year warranty from the date of manufacture subject to the absence of misuse, overload or accidental damage. Claims will not be considered if the serial number has been altered or removed. Work under warranty should only be carried out by a Tannoy Professional dealer or service agent. This warranty in no way affects your statutory rights. For further information please contact your dealer or distributor in your country. If you cannot locate your distributor please contact Customer Services, Tannoy Ltd at the address given below.

Customer Services  
Tannoy Ltd.  
Rosehall Industrial Estate  
Coatbridge  
Strathclyde  
ML5 4TF  
Scotland

Telephone: 01236 420199 (National)  
+44 1236 420199 (International)  
Fax: 01236 428230 (National)  
+44 1236 428230 (International)  
e-mail: [prosales@tannoy.com](mailto:prosales@tannoy.com)

DO NOT SHIP ANY PRODUCT TO TANNOY WITHOUT PREVIOUS AUTHORISATION

Our policy commits us to incorporating improvements to our products through continuous research and development. Please confirm current specifications for critical applications with your supplier.

**EASE™** Data for Tannoy Professional products available on request.

#### 14. Wall Mounting Bracket - Assembly Instructions

A dedicated wall mounting bracket (Part No. 8000 0671) is available for the i15. The design of the bracket allows the loudspeaker to be mounted either in portrait or landscape orientation:-

Landscape mounting - Remove two of the original M8 countersunk screws on one side of the cabinet, place the T-Bar in position and fix in place using the two cap-head bolts which are included along with the bracket hardware, remembering to use the washers and locking washers which are also provided. Assemble the bracket as shown on the diagram below. It is imperative that the bracket is fixed soundly to the wall. Be sure to use the correct fixings (e.g. Rawbolt, Rawplug) according to the wall type.

Portrait mounting - Using a hacksaw, cut along the indents on the T-bar. Carry out the above instructions, removing two of the original M8 countersunk screws on **top** of the cabinet.

**Exploded View of Bracket**

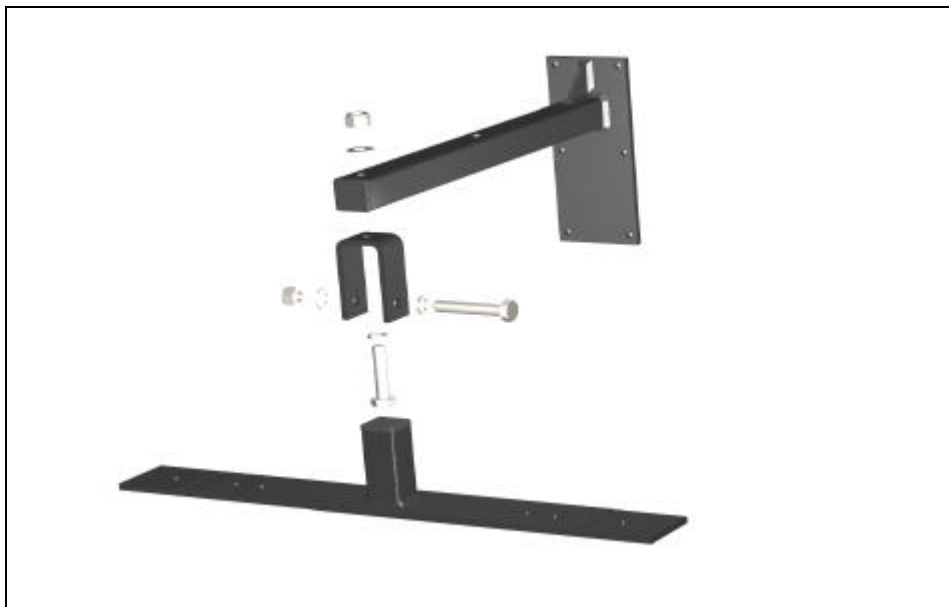

**Assembled View of Bracket**

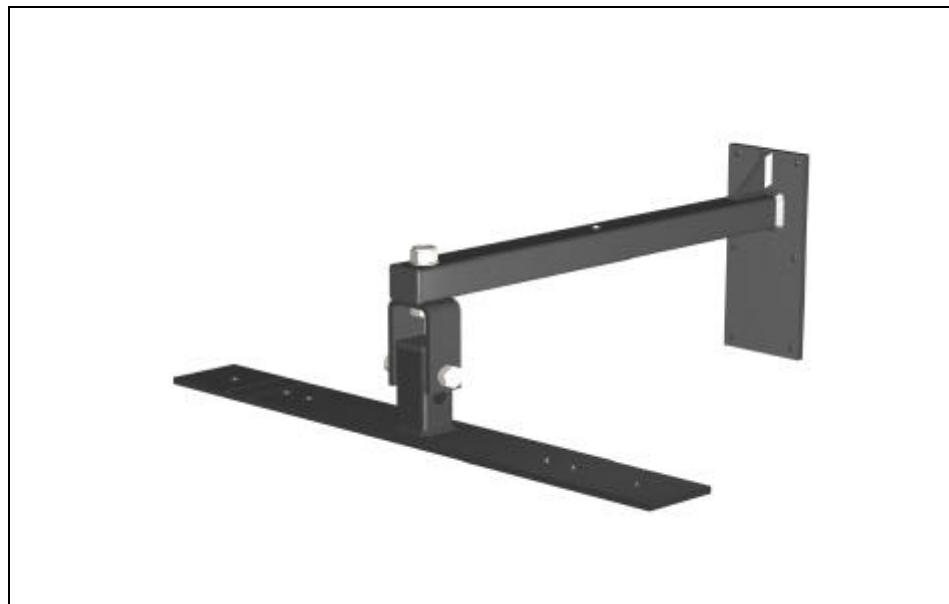

# TANNOY®

professional

## Declaration of Conformity

The following apparatus is/are manufactured in the United Kingdom by Tannoy Ltd of Rosehall Industrial estate, Coatbridge, Scotland, ML5 4TF and conform(s) to the protection requirements of the European Electromagnetic Compatibility Standards and Directives relevant to Domestic Electrical Equipment. The apparatus is designed and constructed such that electromagnetic disturbances generated do not exceed levels allowing radio and telecommunications equipment and other apparatus to operate as intended, and, the apparatus has an adequate level of intrinsic immunity to electromagnetic disturbance to enable operation as specified and intended.

Details of the Apparatus: Tannoy Contractor Loudspeaker  
Model Number: i15

Associated Technical File: EMCi15

Applicable Standards: EN 50081-1 Emission  
EN 50082-1 Immunity

Signed:



Position: Technical Manager  
Tannoy Professional

Date: 16<sup>th</sup> July 1998

For Tannoy Ltd

---

## Tannoy Loudspeakers are manufactured in Great Britain by :

Tannoy Ltd, Rosehall Industrial Estate, Coatbridge,  
Strathclyde, ML5 4TF, SCOTLAND  
Telephone: +44 (0)1236 420199 Fax: +44 (0)1236 428230  
Internet: <http://www.tannoy.com>

Tannoy North America Inc. 335 Gage Avenue, Kitchener, Ontario, CANADA, N2M 5E1  
Telephone: (519) 745 1158 Fax: (519) 745 2364

Tannoy Nederland BV, Anthonetta Kuijistraat 19, 3066 GS, Rotterdam THE NETHERLANDS  
Telephone: (010) 2860554 Fax: (010) 2860431

Issue 3 Part No. 6481 0285